

INSTALLATION AND OPERATION GUIDELINES

FOR REVERSE OSMOSIS SYSTEMS
**ECOSOFT ROBUST 1000, ROBUST 1500,
ROBUST PRO, ROBUST 3000**

ИНСТРУКЦИЯ ПО ПОДКЛЮЧЕНИЮ И ЭКСПЛУАТАЦИИ

СИСТЕМ ОБРАТНОГО ОСМОСА
**ECOSOFT ROBUST 1000, ROBUST 1500,
ROBUST PRO, ROBUST 3000**

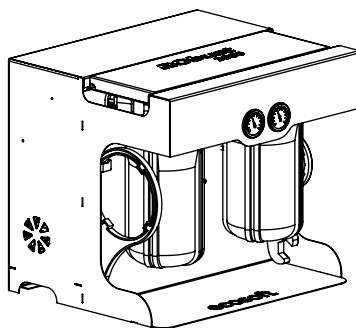
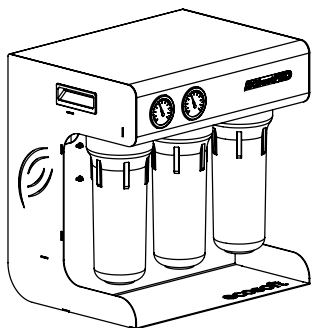
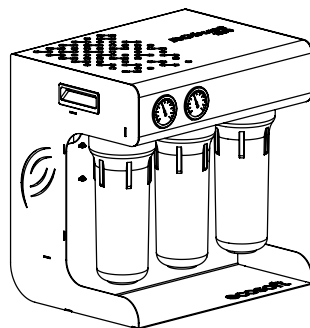
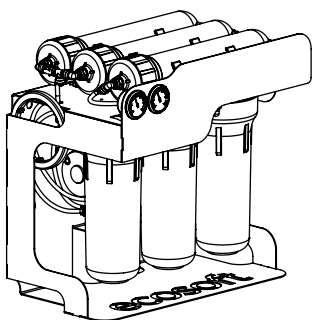

Carefully read this manual before installing the system.

Do not open plastic bag with reverse osmosis system components before you make sure it contains all parts. Missing part claims will not be accepted if the package is broken.

The manufacturer reserves the right to amend design or components of the product, if such amendment does not result in deterioration of its quality and performance.

CONTENTS

1	Application	4
2	Specifications and components	7
2.1	Technical specifications	7
2.2	Feed water requirements	8
2.3	Reverse osmosis systems components	9
3	Installation diagrams	13
3.1	ECOSOFT ROBust base model	13
3.2	ECOSOFT ROBust with pressure tank	13
3.3	ECOSOFT ROBust with pressure tank and ultraviolet unit	14
4	Installation steps	14
4.1	Installation conditions check	14
4.2	Installation	14
5	Post-installation	16
6	Operation	17
6.1	Average lifespan of systems components	18
6.2	Filters replacement	18
6.3	Membrane replacement	19
7	Sanitization	19
8	Troubleshooting	20
9	Maintenance record	22
10	Health and environment safety information	24
11	Transportation and storage	24
12	Warranty	24
13	Authorized services in your area	26

1. APPLICATION

Robust reverse osmosis systems are designed for water purification using reverse osmosis membranes — special semipermeable membranes that allow purifying tap water from all harmful impurities, including nitrates and viruses (see Figure 1 below).

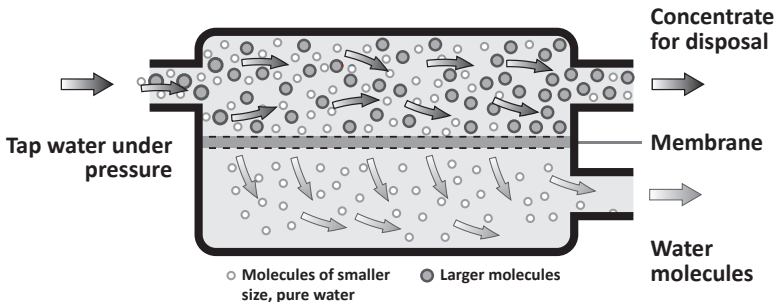

Figure 1. Reverse osmosis process illustration

RObust is a multistage direct flow filtration system, which operates according to the following scheme:

- Feed cold water first undergoes pre-filtration (1st pre-filter in the Robust 3000 system or 1st and 2nd pre-filters in other systems) where it is stripped of suspended particles (rust, sand, hemp strands etc.).
- The pressure booster pump feeds water to the reverse osmosis membranes mounted in parallel or in series. If the supply of feed water is cut off or the input pressure is lowered below 0.15-0.2 bar, a low-pressure switch is triggered, closes the inlet valve and turns off the pump. Even when the purified water faucet is opened, the system will not start until the supply of feed water is restored with sufficient pressure.
- Permeate (purified water) goes to purified water outlet or pressure tank outlet (if installed), passing through the carbon post-filter, and the concentrate — through the flow restrictor is discharged into the drain.
- RObustPro system is equipped special RObustPro replacement filter allows to get water with a small content of magnesium and calcium, which enhance the extraction of coffee flavor and aroma components.

High pressure switch installed before the post-filter reads pressure in permeate line and starts the reverse osmosis system when the pressure drops (due to taking of some water from the pressure tank or opening purified water faucet). When the system switches on, entry solenoid valve is opened and booster pump is powered up, which allows feed water into the system. When purified water faucet is closed, pressure starts to build up, closes high pressure switch turns off the system.

On the Robust system front panel there are two pressure gauges. One shows the water pressure after the pre-filters, and the second shows the pressure after the pump in the membrane unit. The panel also provides information on requirements, recommendations for resolving possible problems if requirement are not met.

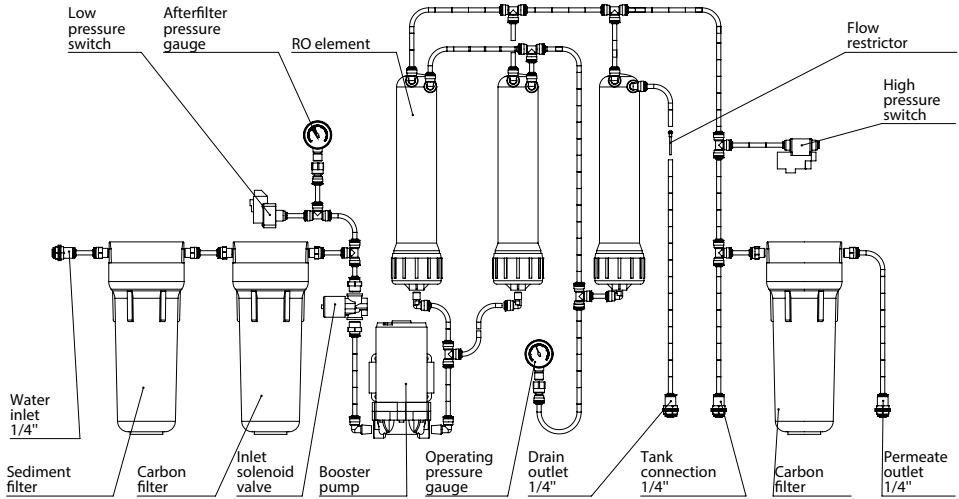

Figure 2. ROust 1000

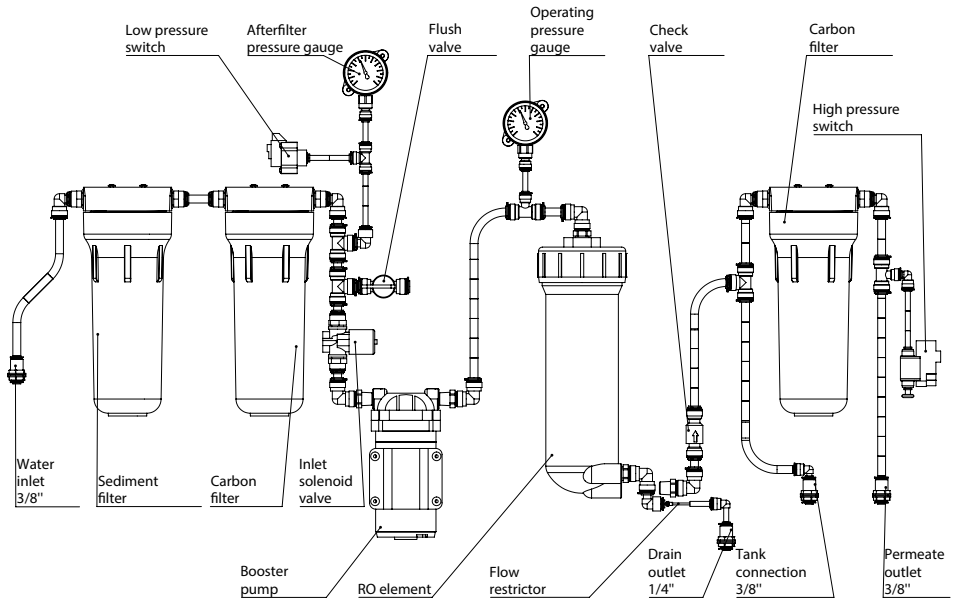

Figure 3. ROust 1500

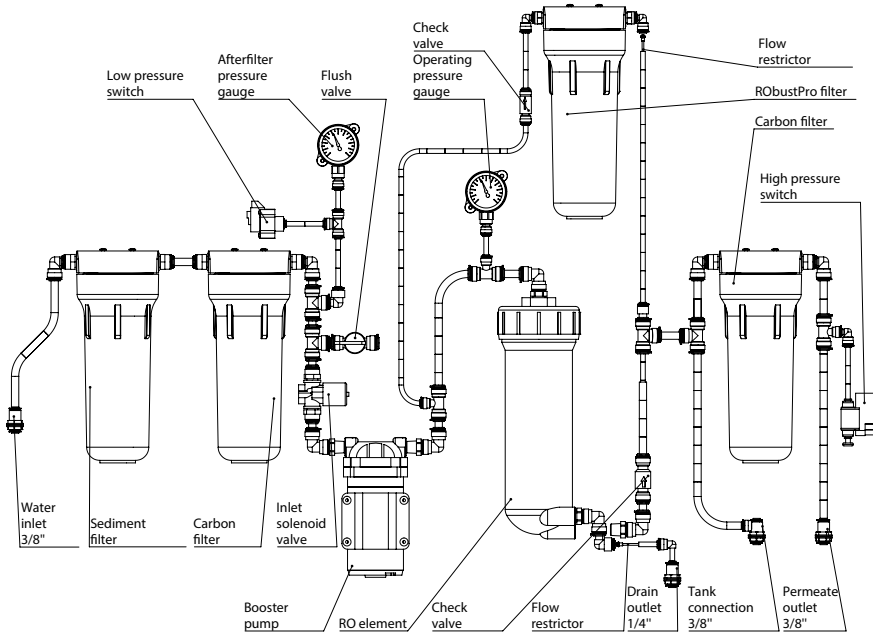

Figure 4. ROBUST PRO

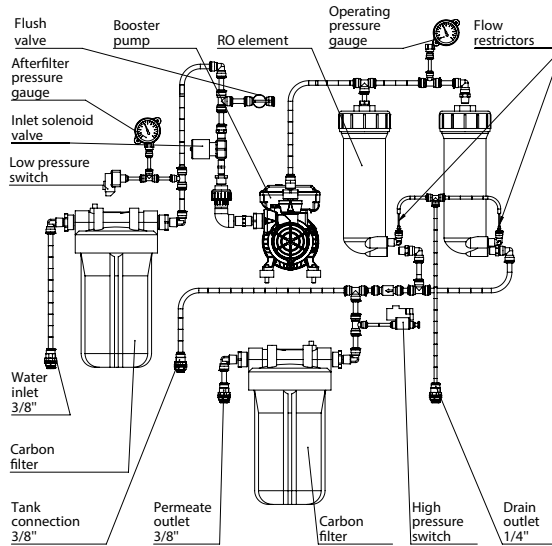

Figure 5. ROBUST 3000

2. SPECIFICATIONS AND COMPONENTS

2.1 TECHNICAL SPECIFICATIONS

Parameter	Value			
	RObust 1000	RObust 1500	RObust Pro	RObust 3000
Purified water flow rate ¹ , L/h	55–60	70–75	70–75	145–150
Feed water flow rate, L/h	110–125	140–150	140–150	290–310
Concentrate flow rate, L/h	55–65	70–75	70–75	145–160
Inlet water pressure, bar	2,0–5,0 ²			
Operating pressure, bar	5,0–7,0			
Feed water temperature, °C	+4...+30 ³			
Ambient air temperature, °C	+5...+40 ³			
Connection to water mains	½"			
Overall dimensions, H × W × D, mm	420x425x220	420x410x305	420x410x305	445x480x380
Weight, kg, max.	6	9	10	25
Electrical rating	230 V, 50 Hz			
Power consumption, W, max.	80	80	80	250
Ingress protection rating	IP 54			

¹ At feed water TDS of 1000 ppm and temperature of feed water of 25 °C, ±10%.

² If pressure of water in your system does not meet requirement, install a pressure booster pump to raise it. If water pressure exceeds the upper limit, install a pressure regulator before the RObust.

³ Using the RObust with feed water temperature between +20 and +30 °C produces a lower rejection rate and higher flow rate, which yields higher TDS of purified water. Using the system with feed water above +30 °C is advised against.

2.2 FEED WATER REQUIREMENTS

Parameter	Value ¹	
	ROBust Pro	ROBust 1000, ROBust 1500, ROBust 3000
pH	6,5...8,5	
TDS, ppm	250-500	< 1500
Total hardness	100–400 ppm CaCO ₃	< 500 ppm CaCO ₃
Alkalinity	100–200 ppm CaCO ₃	< 325 ppm CaCO ₃
Active chlorine, ppm	< 0,5	
Total iron, ppm	< 0,3	
Total manganese, ppm	< 0,05	
Chemical oxygen demand, ppm O ₂	< 5	
Total microbial count (TMC), (CFU per 1 mL)	< 100	
E. coli (CFU per 100 mL)	None	

¹ If feed water quality does not meet specified requirements, membrane and filter service life may decrease. If aiming to purify raw water (well water/ground water etc.), it is recommended to carry out detailed water analysis. If any constituents exceed the above limitations, it is advisable to install a special filter upstream of your reverse osmosis system. Consult professional water treatment specialist for proper selection of an appropriate filter for your water.

2.3 REVERSE OSMOSIS SYSTEMS COMPONENTS

ROBUST 1000

1) Assembled filter

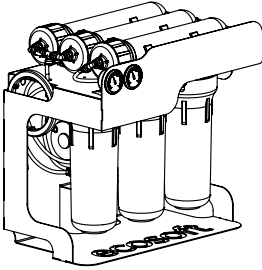

2) Pre-filters and post-filter

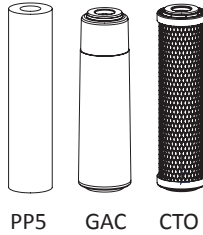

3) Reverse osmosis membranes

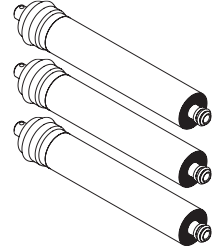

4) Feed adapter

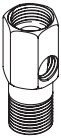

5) Drain saddle

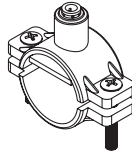

6) Purified water faucet

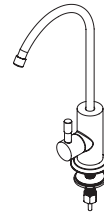

7) Feed valve

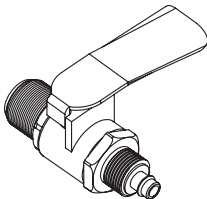

8) Set of tubes and fittings



9) Service wrenches



ROBUST 1500

1) Assembled filter

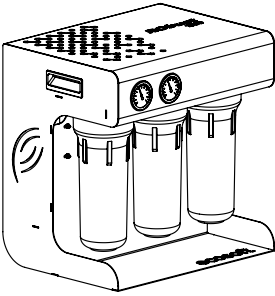

2) Pre-filters and post-filter

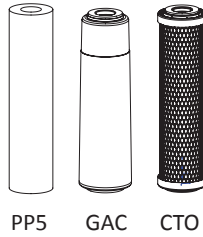

3) Reverse osmosis membrane

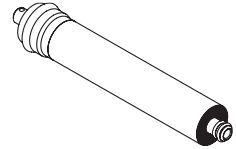

5) Drain saddle

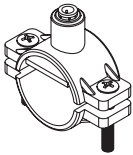

5) Feed valve

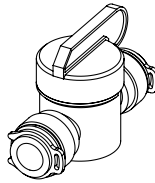

6) Purified water faucet

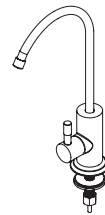

8) Set of tubes and fittings



9) Service wrench

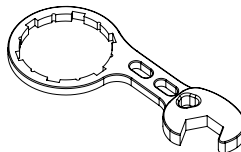

ROBUST PRO

1) Assembled filter

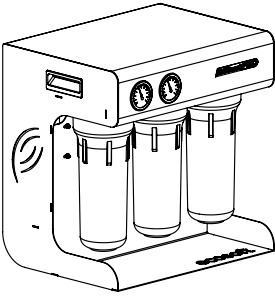

2) Pre-filters and post-filter

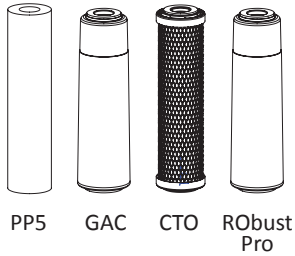

3) Reverse osmosis membrane

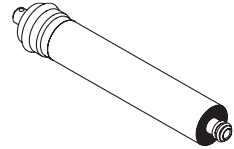

5) Drain saddle

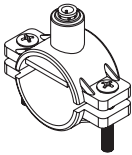

5) Feed valve

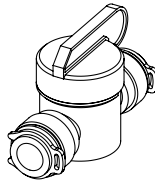

6) Purified water faucet

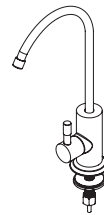

8) Set of tubes and fittings



9) Service wrench

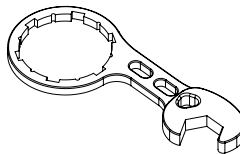

ROBUST 3000

1) Assembled filter

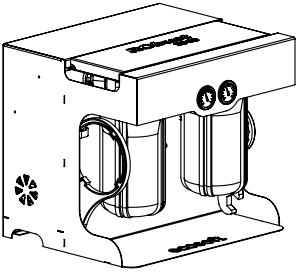

2) Pre-filter and post-filter

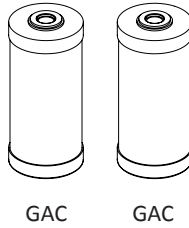

3) Reverse osmosis membranes

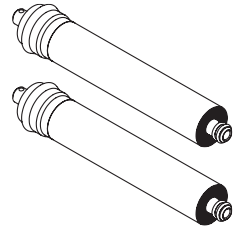

5) Drain saddle

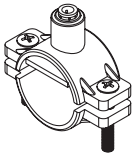

5) Feed valve

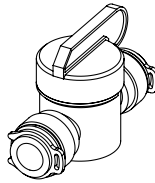

8) Set of tubes and fittings



7) Service wrenches

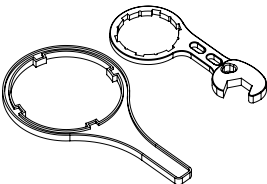

3. INSTALLATION DIAGRAMS

3.1. ECOSOFT ROBUST BASE MODEL

For simplicity of installation, the input and output ports in all ROust systems are arranged in the same order.

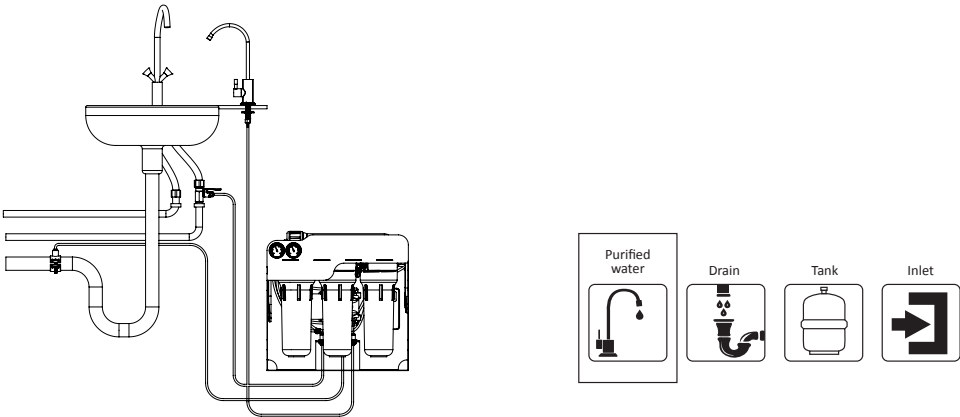

Purified water. Tube from pure water outlet to the purified water faucet.

Pressure tank. Not connected and muffled.

Drain. Tube from the drain outlet to the drain saddle.

Inlet. Water supply tube from the water main.

3.2. ECOSOFT ROBUST WITH PRESSURE TANK

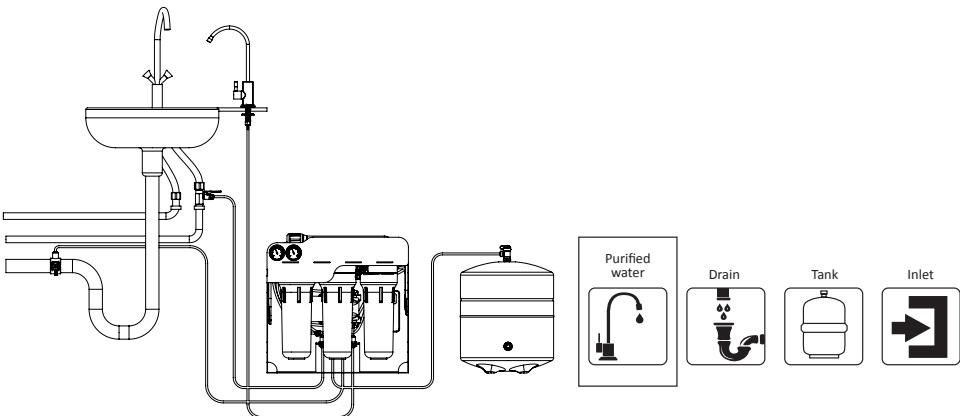

Purified water. Tube from the pure water outlet to the purified water faucet.

Pressure tank. Tube from the tank outlet to the valve on the tank.

Drain. Tube from the drain outlet to the drain saddle.

Inlet. Water supply tube from the water main.

3.3. ECOSOFT ROBUST WITH PRESSURE TANK AND ULTRAVIOLET UNIT

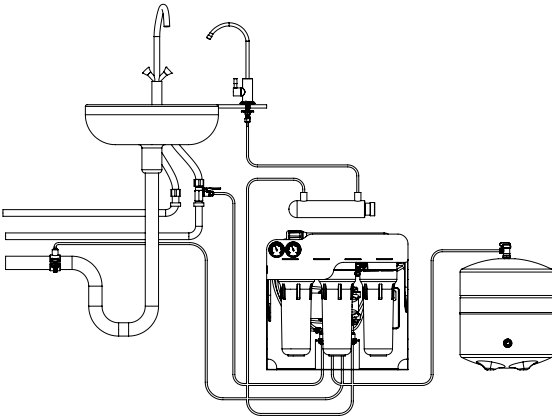

Purified water. Tube from the pure water outlet to the ultraviolet unit.

Pressure tank. Tube from the tank outlet to the valve on the tank.

Drain. Tube from the drain outlet to the drain saddle.

Inlet. Water supply tube from the water main.

Ultraviolet unit*. The tube from the UV unit outlet to the purified water faucet.

*UV unit — optional equipment, not included in the delivery.

The system must be connected by the service center specialist.

4. INSTALLATION STEPS

Carefully read this manual before installing the reverse osmosis system.

4.1. INSTALLATION CONDITIONS CHECK

Check that feed water meets requirements in p. 2.2.

If the water quality does not meet requirements, refer to a water treatment specialist company for assistance selecting the appropriate water filtration product for normalizing feed water quality. Before proceeding with the installation, ensure there is enough space for the assembled system. If using pressure tank, provide room for it as well. In case of shortage of space, pressure tank can be removed to the distance of connecting tube length.

Install the reverse osmosis system in accordance with below procedure.

4.2. INSTALLATION

CAUTION! This product has been factory tested for leaks, and may contain residual moisture. Before installation of tubing, filters, and membranes, wash your hands with antibacterial soap. Ensure that the installation place is shielded from direct sunlight and removed from heating appliances.

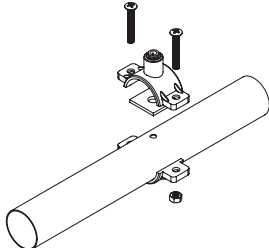
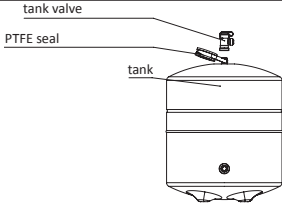
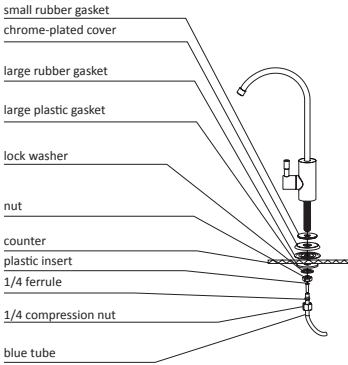
1	Remove the reverse osmosis system from and the box check that all parts are inside the bag.
2	Shut off water supply in place of installation and open a water tap for 1 minute to relieve pressure in the system. Then close the tap.
3	<p>Drain saddle fits most standard drain pipe. Install the drain saddle on drain pipe as follows. Bore 5 mm hole in the drain pipe, apply rubber gasket with sticky base (included in the package). Install drain saddle on top of the gasket so that push-fit fitting in the saddle is located precisely above the hole in drain pipe. Tighten nuts on drain saddle fasteners with a wrench. Insert black tube in the push-fit fitting in drain saddle. Connect the other end of black tube with drain port of the RO system's push-fit port rack.</p> 
4*	<p>Put a few turns of PTFE tape on tank nipple thread. Screw tank valve on the tank nipple. Turn the valve fully off.</p> <p>NOTE! Test air pressure in the empty tank bladder. It should be 0.6–1.0 bar. If necessary, use air pump with to inflate the bladder. If pressure is too high already, push on the valve stem's core to relieve it.</p> 
5	Install the faucet.
5.1	<p>To install purified water faucet bore a 12,5 mm diameter hole in desired location on sink or countertop.</p> <p>CAUTION! Metal shavings can damage your sink, remove them carefully once you have finished drilling. If the mounting surface is stone or ceramic, use a carbide drill bit.</p> <p>5.2 Mount the faucet over the hole on top of small rubber washer, chrome plated base, and large rubber washer. Fix the faucet firmly with plastic washer, lock washer, and nut put on the faucet shank underneath sink surface.</p> <p>5.3 Put compression nut on free end of blue tube, then put on ferrule and put insert inside the tube.</p> <p>5.4 Push the end of blue tube inside the shank bottom, seat the ferrule against shank bottom and screw compression nut snugly on shank thread. The faucet should now be firmly fixed on top of sink, and blue tube tightly seated in compression fitting at the bottom of faucet shank.</p> 
6	Install replacement filters to the 1st and 2nd housings (left to right).
7	Install the housings back on the system. Hand tighten only.

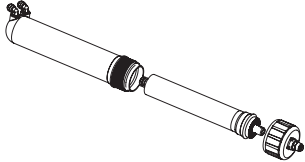
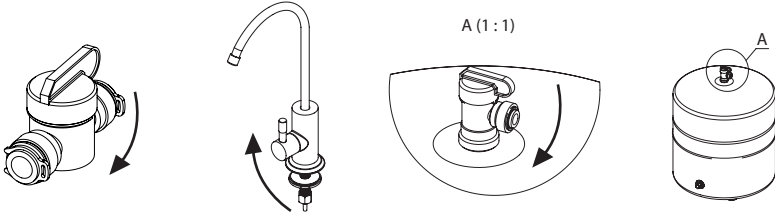
<p>8</p>	<p>Start rinsing pre-filters: RObund 1000: disconnect the inlet tubes from the covers of the two first membrane holders and guide them into the bucket. Open system's feed valve. Pass the required volume of water until there are no carbon fines in rinsewater. Install the free tube ends back in push-fit fittings and lock with locking clips. RObund 1500, RObund Pro, RObund 3000: open a special rinse valve and pass the required volume of water to the bucket until there are no carbon fines in rinsewater.</p>
<p>9</p>	<p>Install all membranes in membrane housings. CAUTION! When installing reverse osmotic membrane, do not take it out of the bag. Cut the bag at the opposite end to membrane's brine seal, push the membrane inside membrane housing. Do not touch membrane surface at any time.</p> 
<p>10</p>	<p>Open feed valve and purified water faucet for 30 minutes to rinse membranes and other parts of the system. Do not open tank valve at this time. Close the purified water faucet and check all connections for leaks. CAUTION! Inspect the system for leaks every day for the first week after installation. Continue to check periodically onward. When leaving for an extended while, shut off main valve to remove water supply to the system.</p> 
<p>11</p>	<p>Insert the post-filter into housing and screw it. For RObundPro system insert special RObundPro filter and post-filter into the housings and screw them. Open the water supply and purified water faucet for 5-10 minutes to rinse the carbon filter.</p>
<p>12*</p>	<p>Open tank valve and let the system fill it. Open purified water faucet and discard the first tank of purified water. When the tank is drained empty, close the purified water faucet and let the system refill the tank. The water can be used now.</p>

* Skip steps 4 and 12 if installing a tankless system.

5. POST-INSTALLATION

1. Use calibrated TDS meter to test your tap water and purified water total dissolved solids.
2. Verify proper functioning of feed water solenoid. The system must switch off and stop discharging concentrate when pressure tank is full* and purified water faucet is closed.
3. Inspect the system carefully for leaks.
4. Make a record of system installation in maintenance log paragraph 9.
5. *Operation with the pressure tank. When the tank is full, the pump is switched off and the drain stop.

* Skip if using a tankless system.

6. OPERATION

RObust reverse osmosis system should be used for purification of cold water only. Monitoring of the system is carried out based on the readings of pressure gauges and evaluation of production.

Pressure after pre-filters (left pressure gauge). If pressure after pre-filters is less than 1 bar, this may indicate low mains pressure or clogged pre-filters. Test pressure at the feed adapter site. If it exceeds reading on the pressure gauge significantly, replace pre-filters. Otherwise, low feed water pressure is at fault and has to be sorted out. If the 1st pressure gauge displays over 5 bar after the system switches on, power down the system immediately, disconnect water supply, and install a pressure regulator upstream of the system. Then, continue setting up the system. Recommended feed water pressure is 3,5 bar.

Operating pressure (right pressure gauge). If operating pressure in the membrane is lower than 4 bar or falls to the value of the feed water pressure, this can be caused by the following:

- motor power supply fault (possibly due to broken/torn pump motor cord);
- air trapped inside pump's chamber;
- jamming of the pump with solids such as carbon fines (if carbon filter was not properly rinse before use).

Generally, if operating pressure reading on the 2nd pressure gauge falls below its normal range, contact your dealer's service. If pressure on 2nd pressure gauge is over 7 bar, this could be due to pressure regulator failure or the RO system's high pressure switch fault. Contact your dealer's service for help.

Performance. Reduced system flow rate is a sign of exhausted capacity of pre-filters. Untimely replacement of them leads to contamination of membranes and complete loss of their productivity. With a significant drop in system performance, replacement of reverse osmosis membranes is required.

In the event of long breaks in the system operation (more than 2 weeks), disinfect the system as described in paragraph 7 and shut off the water supply to the system.

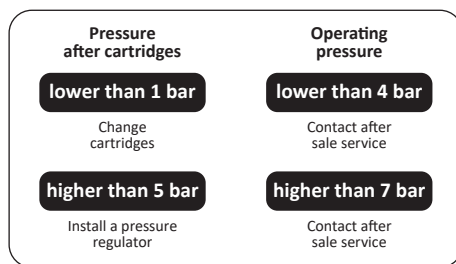

Figure 6. Operating parameters of the system

6.1. AVERAGE LIFESPAN OF SYSTEMS COMPONENTS

Filter type	Service life*			
	RObust 1000	RObust 1500	RObust PRO	RObust 3000
Pre-filters and post-filters**	8 000 L but not less than once in 3 months. Service life depends on feed water quality and intensity of usage	8 000 L but not less than once in 3 months. Service life depends on feed water quality and intensity of usage	5 000 L but not less than once in 3 months. Service life depends on feed water quality and intensity of usage	15 000 L but not less than once in 3 months. Service life depends on feed water quality and intensity of usage
Reverse osmosis membranes	24 000 L but not less than once a year	40 000 L but not less than once a year	40 000 L but not less than once a year	80 000 L but not less than once a year

* Service life depends on quality of feed water.

** In Robust Pro reverse osmosis system all filters should be replaced at the same time.

6.2. FILTERS REPLACEMENT

1	Without disconnecting the system from the mains, turn off the water supply valve on the system, turn the tank ball valve to the "Closed" position. For systems with a purified water faucet: open the tap on the sink, turn off the water supply valve on the system, turn the tank ball valve to the "Closed" position. For systems without a faucet, open the tap for supplying purified water to the consumer.
2	Wash your hands with antibacterial soap thoroughly.
3	After water has stopped running from purified water faucet, unplug the RO system from the mains and screw off the three filter housings. Take care as the bowls will be full of water.
4	Remove spent filters.
5	Wash the bowls thoroughly with non-aromatic soap, and then rinse with water.
6	Install new filters in bowls in the correct sequence from left to right: polypropylene, GAC, carbon block (for systems RObust 1000, 1500, Pro), or two activated carbon filters (for RObust 3000). For the RObustPro system also insert a special RObustPro replacement filter.
7	Start rinsing pre-filters: RObust 1000: disconnect the inlet tubes from the covers of the two first membrane holders and guide them into the bucket. Open system's feed valve. Pass the required volume of water until there are no carbon fines in rinsewater. Install the free tube ends back in push-fit fittings and lock with locking clips. RObust 1500, RObust Pro, RObust 3000: open a special rinse valve and pass the required volume of water to the bucket until there are no carbon fines in rinsewater.

6.3. MEMBRANE REPLACEMENT

(Performed by water filter service specialist)

1	Shut off feed water valve, close pressure tank valve if used.
2	Open purified water faucet to relieve pressure in the system. Remove power from the system.
3	Unplug tube from each membrane housing cap. Screw off the housing caps. Extract used membranes from membrane housings and take note of their orientation inside the housings.
4	Install new RO membranes in housings observing proper orientation of each. CAUTION! Do not remove plastic bag when installing membrane. Make a cut in the head end of bag and push the membrane out of the bag into the housing. Do not touch membrane surface with your hands.
5	Screw on membrane housing caps.
6	Plug tubes back in the housings.
7	Open feed valve. Restore power supply to the system.
8	Let the system run for 30 minutes to flush out membrane preservative. Then, close purified water faucet and open pressure tank valve if used.

7. SANITIZATION

Sanitization of the reverse osmosis system is recommended after it has been in operation for an extended period (over 6 months) or when the system is to be shut down for 3 weeks or longer. It is also advisable to sanitize the system when replacing filters. It is recommended to use tablets based on active chlorine for sanitization.

Sanitization is performed by water filter service specialist.

1	Shut off feed water valve and tank valve if used.
2	Remove and discard the pre-filter and post-filter replacement elements.
3	Unscrew cap of RO element housing and remove RO element using needlenose pliers if necessary. Put the membrane into a tight bag and store in refrigerator at +2...+5°C.
4	Screw back pre-filter sumps, screw on membrane housing cap, and connect the tube from the faucet directly to the union tee without post-filters.
5	Put a chlorine tablet in the 1st sump. Fill the sump with water and screw on.
6	After 15 minutes, open the drinking water faucet and feed valve.
7	When water running from the faucet starts to smell like chlorine, close both the faucet and feed valve.
8	Leave the system for 2-3 hours.
9	Open clean water faucet and feed water valve and let water run until bleach odor is gone.
10	Install all consumable parts back into the system. Open tank valve if used and feed water valve.
11	Drain water until chlorine odor cannot be smelt.

8. TROUBLESHOOTING

Problem	Possible cause	Method of handling
Fitting leak	Tube is not connected tightly	Remove and reinstall the tube properly
Filter housing leak	O-ring seal is missing or misaligned	Check that the O-ring seal is correctly seated in circular groove inside bowl
	Filter bowl is not tightened	Hand tighten the housing till snug
Purified water flow rate is lower than normal	Low feed water pressure	Check the inlet pressure
	Clogged pre-filter	Replace pre-filter
	Clogged membranes	Replace membranes
	Bent flexible tube	Inspect the tube
The system keeps switching on and off and will not stop	Surges in feed water pressure just above low pressure switch setting	Eliminate pressure surges. Check supply water piping for clogs and other obstructions and eliminate if present
The system will not switch on	Feed valve or main shutoff valve is closed. Low pressure switch failure	Open all valves on supply water pipes. Check for clogs/obstruction. Replace low pressure switch. Verify proper electrical contact
The system will not switch off	High pressure switch failure	Replace high pressure switch. Verify proper electrical contact
The system has switched off but continues to send water to drain	Solenoid valve failure	Replace the solenoid valve

Recovery has decreased significantly	Clogged pre-filter	Replace pre-filter
	Clogged membranes	Replace membranes
Water is not discharged to drain when the system is on	Clogged flow restrictor	Clean flow restrictor or replace if necessary
Purified water is hazy or cloudy but becomes clear after a few minutes	Air bubbles trapped in the system	Some air may remain in the system for a few days after installation and will go away on its own. Air bubbles may appear in water if there is a large difference between feed water and ambient temperature
Purified water has a taste or odor	Expired post-filter	Replace post-filter
	Membrane preservative was not flushed fully after the installation	Flush the RO system and discard all rinse water
	Contamination of the system	Sanitize the system according to instructions in p. 7
	Contamination of pressure tank	Sanitize pressure tank. Pressure tank may become contaminated if filters or membranes are used beyond their service life
Pressure tank is not full when the system switches off	Tank bladder is overinflated	Pressure in empty tank bladder must be 0.6–1.0 atm. Release some pressure if necessary. Operation is performed by water filter service specialist
	Tank valve is closed	Check tank valve position

9. MAINTENANCE RECORD

It is strongly advised to keep record of important information in the following form. This information will help your dealer's specialist if the system needs to be serviced. This information may also request by the product vendor if there should be any deviations from normal operation.

ROBUST RO SYSTEM INSTALLATION REPORT FORM

Step	Result	Remarks
Date of commissioning		
Water pressure at the inlet, bar		
Carbon fines fully flushed from filters, Y/N		
Preservative fully flushed from membranes, Y/N		
System disinfected, Y/N		
Water pressure in membrane array, bar		
Air pressure in pressure tank bladder, bar		
Feed water temperature, °C		
Purified water flow, L/h		
Concentrate discharge flow, L/h		
Connection to water supply, standard/other		
Pressure testing duration, minutes		
Additional work and installed equipment		
Installation service provider		
The company's address		
The company's contact details		

Installation job was completed; the product was tested and proved functional and complete. No claims were made, as attested to by signatures below:

Owner _____ Signature _____ Date _____

Installer _____ Signature _____ Date _____

ROBUST RO SYSTEM MAINTENANCE REPORT FORM

Step	Result	Remarks
Date of service		
Specification of service		
Used consumables: product name, lot, date of manufacture		
System disinfected, Y/N		
Carbon fines fully flushed from filters, Y/N		
Preservative fully flushed from membranes, Y/N		
Water pressure at the inlet, bar (psi)		
Water pressure in membrane array, bar (psi)		
Air pressure in pressure tank bladder, bar (psi)		
Feed water temperature, °C (°F)		
Purified water flow, L/h (gpm)		
Concentrate discharge flow, L/h (gpm)		
Pressure testing duration, minutes		
Additional work and installed equipment		
Maintenance service provider		
The company's address		
The company's contact details		

Maintenance/repair was completed, the product was tested and proved functional and complete. No claims were made, as attested to by signatures below:

Owner _____ Signature _____ Date _____

Installer _____ Signature _____ Date _____

10. HEALTH AND ENVIRONMENT SAFETY INFORMATION

This product does not produce any chemical, electrochemical, or radiological impact on the environment. The product is not recognized to have any hazardous impact on human body, and meets requirements of relevant sanitary legislation for its intended scope of use.

11. TRANSPORTATION AND STORAGE

The product can be shipped by any means of transport (except unheated during cold seasons in colder climates) in accordance with the rules of goods transportation applicable to each type of transport. Observe handling labels when handling and shipping the product. The product should be stored indoors protected from mechanical damage, moisture, and aggressive chemicals, in vendor's original packaging, at an ambient temperature in the range of +5...+40 °C and relative humidity up to 80%, not closer than 1 m to any heating appliances.

12. WARRANTY

Thank you for purchasing Ecosoft reverse osmosis system! We hope that this product will serve you long and let you and your family enjoy high quality pure drinking water.

The product vendor guarantees that the system has no manufacturing defects, and no defects will arise within warranty period from the date of purchase provided that the technical requirements and operating conditions specified in this manual are strictly adhered to.

Please carefully read this Instruction manual, warranty liabilities, check that warranty card is filled and complete with a proof of purchase (cash receipt, invoice, or installer's receipt). Warranty card will not be valid if the product model, date of purchase, and dealer's stamp are not present and clear. Carefully read the installation and operation parts of the manual before installing or use services of a qualified professional.

The vendor shall not be held liable for any property damage or other loss, including lost profits, accidental or due to use or inability to use this product. Liability of the vendor shall not exceed value of the product.

Warranty period: 12 months from the date of purchase from a retail establishment.

The warranty does not cover:

- Replaceable parts (filters, reverse osmosis membranes, carbon post-filter, mineral post-filter, and other consumable parts that may be included with this system);
- Electrical equipment that is not properly earthed or powered without a voltage regulator where there is a risk of voltage surges;
- Replaceable parts that require replacement due to wear;
- Any malfunctions arising due to non-timely replacement of spent consumables that exceeds terms indicated in this manual, and use of consumables from other vendors.

Claims of water quality issues including taste, odor, and other properties, will only be accepted with water test report issued by an accredited laboratory.

Cases not covered under this warranty shall be resolved under current local legislation.

Installation and maintenance service provider is not responsible for the customer’s plumbing and fixture issues. Unsatisfactory condition of supply water pipework, valves, and fittings, or failure to meet installation site specifications provided herein can be considered grounds for refusal to install the product.

NOTE! The vendor will not be responsible for any issues caused by incorrect installation and maintenance of the system if the customer installs the system themselves.

Product	Code	Date of sale	Mark of sale, the seller	A note of the warranty repairs performance
ROBUST 1000				
ROBUST 1500				
ROBUST PRO				
ROBUST 3000				

13. AUTHORIZED SERVICES IN YOUR AREA

Name	Address	Contact details
Area		
Area		
Area		
Area		

FOR NOTES